

**ATTACHMENT 1
CITY OF MERCER ISLAND
ON-SITE DETENTION SYSTEM WORKSHEET
(FOR NEW PLUS REPLACED IMPERVIOUS
AREA OF 9,500 SF OR LESS)**

OWNER: YONG ADDRESS: 2423 63RD AVE SE PREPARED BY: ANSTEY ENGINEERING
 PERMIT #: _____ MERCER ISLAND, WA PHONE: 206-303-7639
 NEW PLUS REPLACED IMPERVIOUS SURFACE AREA (SF): _____ DETENTION PIPE DIA (INCH): 36" DETENTION PIPE LENGTH (FT): 66" ORIFICE #1 DIA 0.5" INCH, ELEV 108.24
 SOIL TYPE: ALDERWOOD TYPE C PIPE MATERIAL: LCPE ORIFICE #2 DIA 1.9" INCH, ELEV 110.64

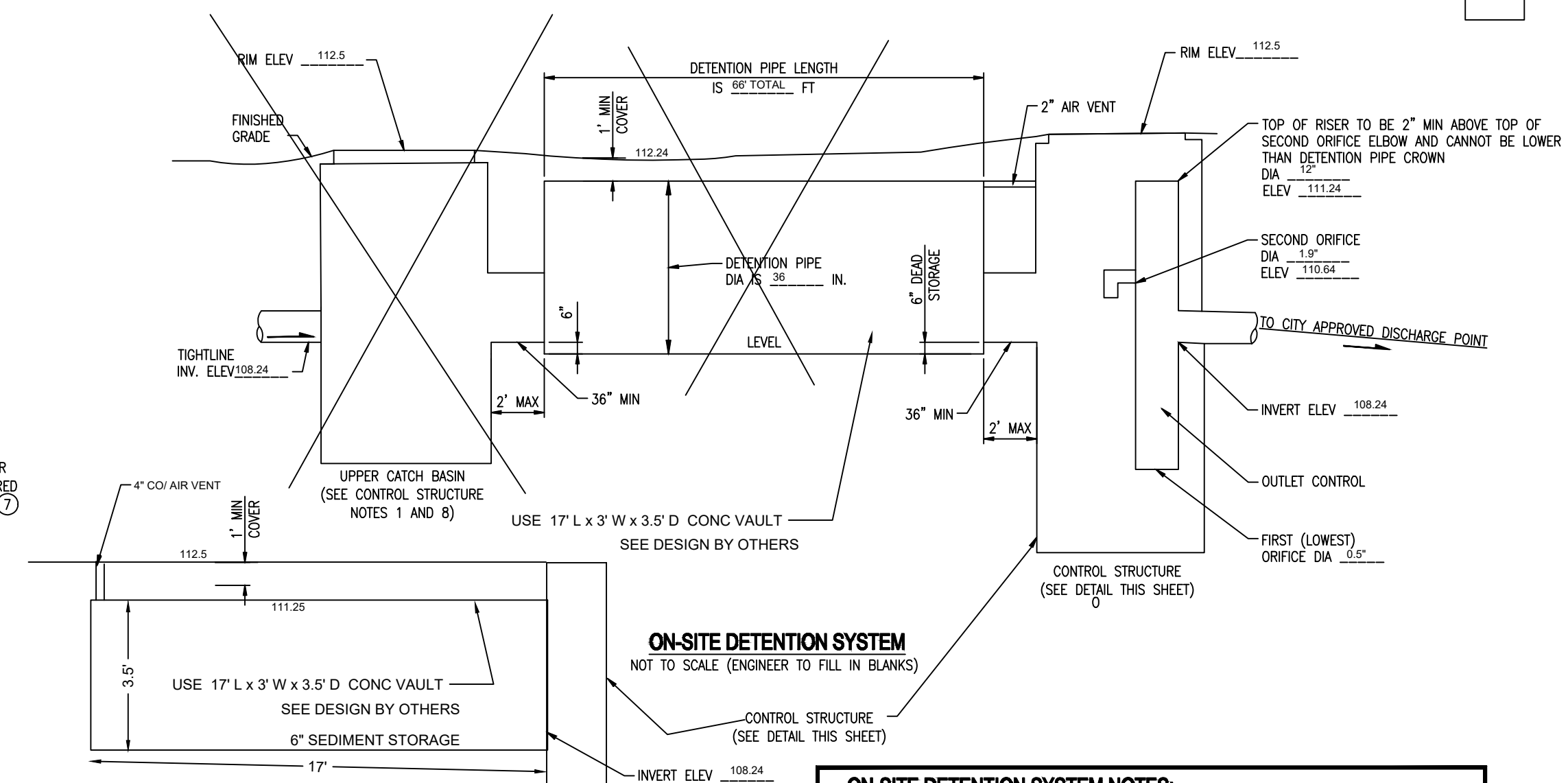
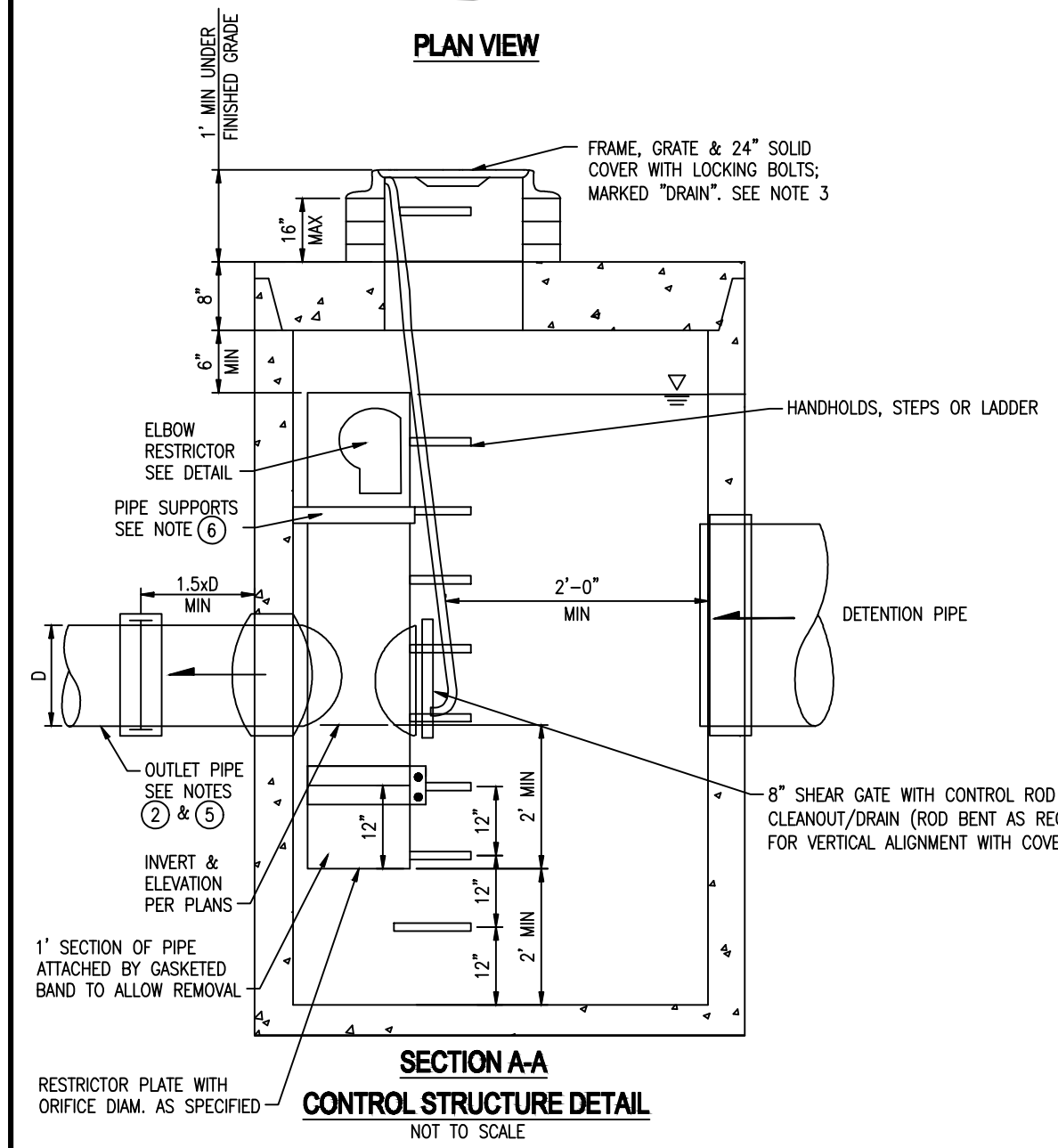
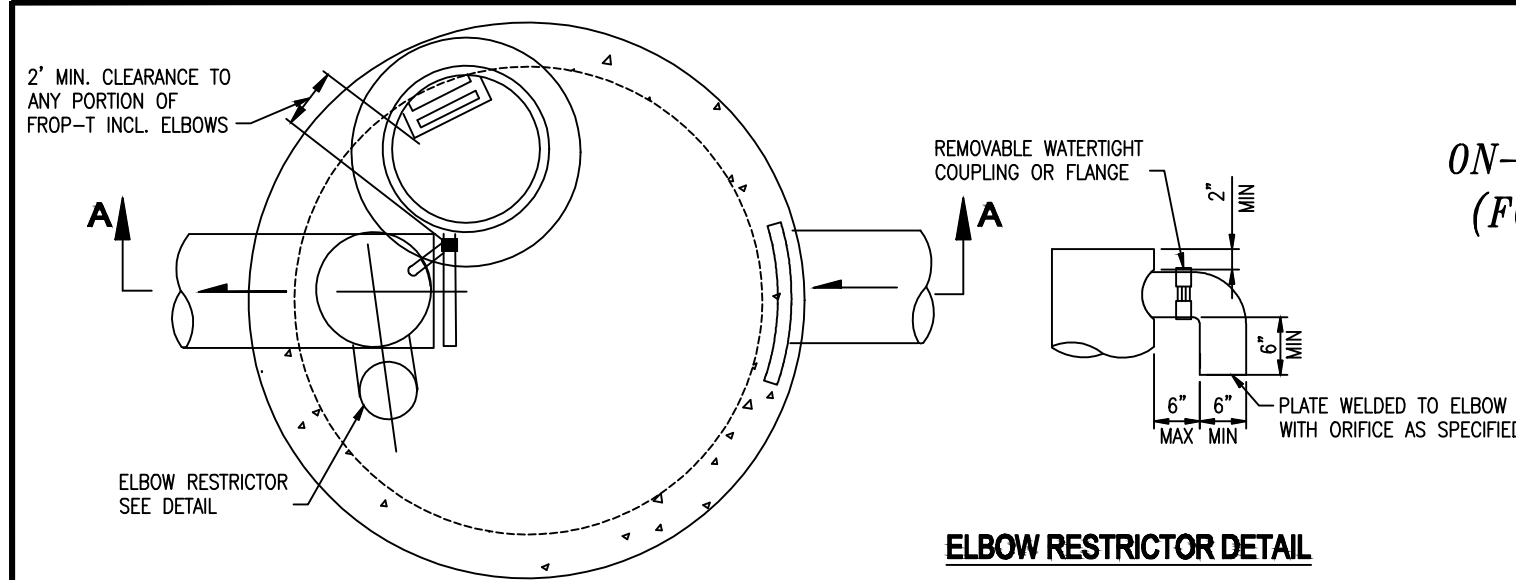

CONTROL STRUCTURE NOTES:

- USE A MINIMUM OF A 54 IN. DIAM. TYPE 2 CATCH BASIN. THE ACTUAL SIZE IS DEPENDENT ON CONNECTING PIPE MATERIAL AND DIAMETER.
- OUTLET PIPE: MIN. 6 INCH.
- METAL PARTS: CORROSION RESISTANT. NON-GALVANIZED PARTS PREFERRED. GALVANIZED PIPE PARTS TO HAVE ASPHALT TREATMENT 1.
- FRAME AND LADDER OR STEPS OFFSET SO:
 - A. CLEANOUT GATE IS VISIBLE FROM TOP;
 - B. CLIMB-DOWN SPACE IS CLEAR OF RISER AND CLEANOUT GATE;
 - C. FRAME IS CLEAR OF CURB.
- IF METAL OUTLET PIPE CONNECTS TO CEMENT CONCRETE PIPE, OUTLET PIPE TO HAVE SMOOTH O.D. EQUAL TO CONCRETE PIPE I.D. LESS 1/4 IN.

- PROVIDE AT LEAST ONE 3 X 0.090 GAUGE SUPPORT BRACKET ANCHORED TO CONCRETE WALL WITH 5/8 IN. STAINLESS STEEL EXPANSION BOLTS OR EMBEDDED SUPPORTS 2 IN. INTO CATCH BASIN WALL (MAXIMUM 3'-0" VERTICAL SPACING).
- THE SHEAR GATE SHALL BE MADE OF ALUMINUM ALLOY IN ACCORDANCE WITH ASTM B 26M AND ASTM B 275, DESIGNATION Z532A; OR CAST IRON IN ACCORDANCE WITH ASTM A 48, CLASS 30B. THE LIFT HANDLE SHALL BE MADE OF A SIMILAR METAL TO THE GATE (TO PREVENT GALVANIC CORROSION). IT MAY BE OF SOLID ROD OR HOLLOW TUBING, WITH ADJUSTABLE HOOK AS REQUIRED. A NEOPRENE RUBBER GASKET IS REQUIRED BETWEEN THE RISER MOUNTING FLANGE AND THE GATE FLANGE. INSTALL THE GATE SO THAT THE LEVEL-LINE MARK IS LEVEL WHEN THE GATE IS CLOSED. THE MATING SURFACES OF THE LID AND THE BODY SHALL BE MACHINED FOR PROPER FIT. ALL SHEAR GATE BOLTS SHALL BE STAINLESS STEEL.
- THE UPPER CATCH BASIN IS REQUIRED IF THE LENGTH OF THE DETENTION PIPE IS GREATER THAN 50 FT.

ON-SITE DETENTION SYSTEM NOTES:

- CALL DEVELOPMENT SERVICES (206-275-7605) 24 HOURS IN ADVANCE FOR A DETENTION SYSTEM INSPECTION BEFORE BACKFILLING AND FOR FINAL INSPECTIONS.
- RESPONSIBILITY FOR OPERATION AND MAINTENANCE OF DRAINAGE SYSTEMS ON PRIVATE PROPERTY IS RESPONSIBILITY OF THE PROPERTY OWNER. MATERIAL ACCUMULATED IN THE STORAGE PIPE MUST BE REMOVED FROM CATCH BASINS TO ALLOW PROPER OPERATION. THE OUTLET CONTROL ORIFICE MUST BE KEPT OPEN AT ALL TIMES.
- PIPE MATERIAL, JOINT, AND PROTECTIVE TREATMENT SHALL BE IN ACCORDANCE WITH SECTION 7.04 AND 9.05 OF THE WSDOT STANDARD SPECIFICATION FOR ROAD, BRIDGE, AND MUNICIPAL CONSTRUCTION, LATEST VERSION. SUCH MATERIALS INCLUDE THE FOLLOWING: LINED CORRUGATED POLYETHYLENE PIPE (LCPE), ALUMINIZED TYPE 2 CORRUGATED STEEL PIPE AND PIPE ARCH (MEETS AASHTO DESIGNATIONS M274 AND M36), CORRUGATED OR SPIRAL RIB ALUMINUM PIPE, OR REINFORCED CONCRETE PIPE, CORRUGATED STEEL PIPE IS NOT ALLOWED.
- FOOTING DRAINS SHALL NOT BE CONNECTED TO THE DETENTION SYSTEM.

Table 1
ON-SITE DETENTION DESIGN FOR PROJECTS BETWEEN 500 SF AND 9,500 SF NEW PLUS REPLACED IMPERVIOUS SURFACE AREA

| New and Replaced ImperVIOUS Surface Area (sf) | Detention Pipe Diameter (in) | Detention Pipe Length (ft) | | Lowest Orifice Diameter (in) ⁽¹⁾ | | Distance from Outlet Invert to Second Orifice (ft) | | Second Orifice Diameter (in) | |
|---|------------------------------|----------------------------|---------|---|---------|--|---------|------------------------------|---------|
| | | B soils | C soils | B soils | C soils | B soils | C soils | B soils | C soils |
| 500 to 1,000 sf | 36" | 30 | 22 | 0.5 | 0.5 | 2.2 | 2.0 | 0.5 | 0.8 |
| | 48" | 18 | 11 | 0.5 | 0.5 | 3.3 | 3.2 | 0.9 | 0.8 |
| | 60" | 11 | 7 | 0.5 | 0.5 | 4.3 | 3.4 | 0.5 | 0.6 |
| 1,001 to 2,000 sf | 36" | 66 | 43 | 0.5 | 0.5 | 2.2 | 2.3 | 0.9 | 1.4 |
| | 48" | 34 | 23 | 0.5 | 0.5 | 3.2 | 3.3 | 0.9 | 1.2 |
| | 60" | 22 | 14 | 0.5 | 0.5 | 4.3 | 3.6 | 0.9 | 0.9 |
| 2,001 to 3,000 sf | 36" | 90 | 66 | 0.5 | 0.5 | 2.2 | 2.4 | 0.9 | 1.9 |
| | 48" | 48 | 36 | 0.5 | 0.5 | 3.1 | 2.8 | 0.9 | 1.5 |
| | 60" | 30 | 20 | 0.5 | 0.5 | 4.2 | 3.7 | 0.9 | 1.1 |
| 3,001 to 4,000 sf | 36" | 120 | 78 | 0.5 | 0.5 | 2.4 | 2.2 | 1.4 | 1.6 |
| | 48" | 62 | 42 | 0.5 | 0.5 | 2.8 | 2.9 | 0.8 | 1.3 |
| | 60" | 42 | 26 | 0.5 | 0.5 | 3.8 | 3.9 | 0.9 | 1.3 |
| 4,001 to 5,000 sf | 36" | 134 | 91 | 0.5 | 0.5 | 2.8 | 2.2 | 1.7 | 1.5 |
| | 48" | 62 | 42 | 0.5 | 0.5 | 3.5 | 2.9 | 1.7 | 1.5 |
| | 60" | 54 | 37 | 0.5 | 0.5 | 4.6 | 3.6 | 1.6 | 1.4 |
| 5,001 to 6,000 sf | 36" | 162 | 109 | 0.5 | 0.5 | 2.7 | 2.2 | 1.8 | 1.6 |
| | 48" | 90 | 59 | 0.5 | 0.5 | 3.5 | 2.9 | 1.7 | 1.5 |
| | 60" | 73 | 49 | 0.5 | 0.5 | 4.6 | 3.6 | 1.6 | 1.4 |
| 6,001 to 7,000 sf | 36" | 192 | 128 | 0.5 | 0.5 | 2.7 | 2.2 | 1.9 | 1.8 |
| | 48" | 102 | 68 | 0.5 | 0.5 | 3.7 | 2.9 | 1.9 | 1.6 |
| | 60" | 84 | 53 | 0.5 | 0.5 | 4.6 | 3.6 | 1.8 | 1.5 |
| 7,001 to 8,000 sf | 36" | 216 | 146 | 0.5 | 0.5 | 2.8 | 2.2 | 2.0 | 1.9 |
| | 48" | 119 | 79 | 0.5 | 0.5 | 3.8 | 2.9 | 2.2 | 1.7 |
| | 60" | 73 | 49 | 0.5 | 0.5 | 4.5 | 3.6 | 2.0 | 1.6 |
| 8,001 to 8,500 sf ⁽²⁾ | 36" | 228 | 155 | 0.5 | 0.5 | 2.8 | 2.2 | 2.1 | 1.9 |
| | 48" | 124 | 84 | 0.5 | 0.5 | 3.7 | 2.9 | 1.9 | 1.8 |
| | 60" | 77 | 53 | 0.5 | 0.5 | 4.6 | 3.6 | 2.0 | 1.6 |
| 8,501 to 9,000 sf | 36" | NA ⁽³⁾ | 164 | 0.5 | 0.5 | NA ⁽³⁾ | 2.2 | NA ⁽³⁾ | 1.9 |
| | 48" | NA ⁽³⁾ | 89 | 0.5 | 0.5 | NA ⁽³⁾ | 2.9 | NA ⁽³⁾ | 1.9 |
| | 60" | NA ⁽³⁾ | 55 | 0.5 | 0.5 | NA ⁽³⁾ | 3.6 | NA ⁽³⁾ | 1.7 |
| 9,001 to 9,500 sf ⁽²⁾ | 36" | NA ⁽³⁾ | 174 | 0.5 | 0.5 | NA ⁽³⁾ | 2.2 | NA ⁽³⁾ | 2.1 |
| | 48" | NA ⁽³⁾ | 94 | 0.5 | 0.5 | NA ⁽³⁾ | 2.9 | NA ⁽³⁾ | 2.0 |
| | 60" | NA ⁽³⁾ | 58 | 0.5 | 0.5 | NA ⁽³⁾ | 3.7 | NA ⁽³⁾ | 1.7 |

Notes:

- Minimum Requirement #7 (Flow Control) is required when the 100-year flow frequency causes a 0.15 cubic feet per second increase (when modeled in WWHM with a 15-minute timestep). Breakpoints shown in this table are based on a flat slope (0-5%). The 100-year flow frequency will need to be evaluated on a site-specific basis for projects on moderate (5-15%) or steep (>15%) slopes.
- Soil type to be determined by geotechnical analysis or soil map.
- Sizing includes a Volume Correction Factor of 120%.
- Upper bound contributing area used for sizing.
- On Type B soils, new plus replaced impervious surface areas exceeding 8,500 sf trigger Minimum Requirement #7 (Flow Control)
- On Type C soils, new plus replaced impervious surface areas exceeding 9,500 sf trigger Minimum Requirement #7 (Flow Control)
- Minimum orifice diameter = 0.5 inches
- in = inch
- ft = feet
- sf = square feet

Basis of Sizing Assumptions:
 Sized per MR48 in the Stormwater Management Manual for Puget Sound Basin (1992 Ecology Manual)
 SBUH, Type 1A, 24-hour hydrograph
 2-year, 24-hour storm = 2 in; 10-year, 24-hour storm = 3 in; 100-year, 24-hour storm = 4 in
 Preredevolved = second growth forest (CN = 72 for Type B soils, CN = 81 for Type C soils)
 Developed = impervious (CN = 98)
 0.5 foot of sediment storage in detention pipe
 Overland slope = 5%

Model # 864G
Internet #100187441
Store SKU #302950



Pro Series 5 in. x 40 in. Channel and Grate Kit with End Outlet

- Pre-assembled channel drain decrease installation time.
- Modular design makes channel drain flexible for longer runs.
- Interlocking channel design eliminates the need for couplings. \$52.43 / each

| NO | DATE | BY | APPR | REVISIONS |
|----|------|----|------|-----------|
| | | | | |
| | | | | |
| | | | | |
| | | | | |

ANSTEY ENGINEERING
 ae 8627 NE 180th Street
 Bothell, WA 98011
 Ph: 206-303-7639
 Email: benanstey@ansteyengineering.com

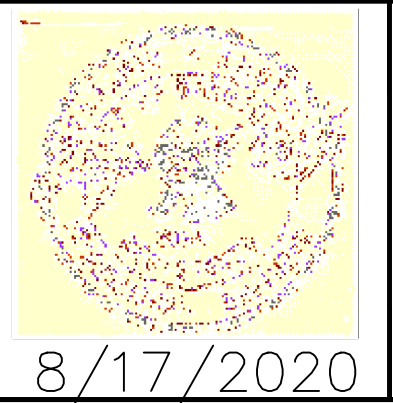

Approved By
 BPA 12/17/19 DESIGNED BY DATE
 BPA 12/17/19 DRAWN BY DATE
 CHECKED BY DATE

MINGQIN LI & SUN YONG
 2423 63RD AVE SE
 MERCER ISLAND, WA 98040

**SITE & DRAINAGE
PLAN DETAILS**

AE2019-84 SHT 2 OF 2